

# Superreel® - Industrial Reel

## EESC750D SERIES

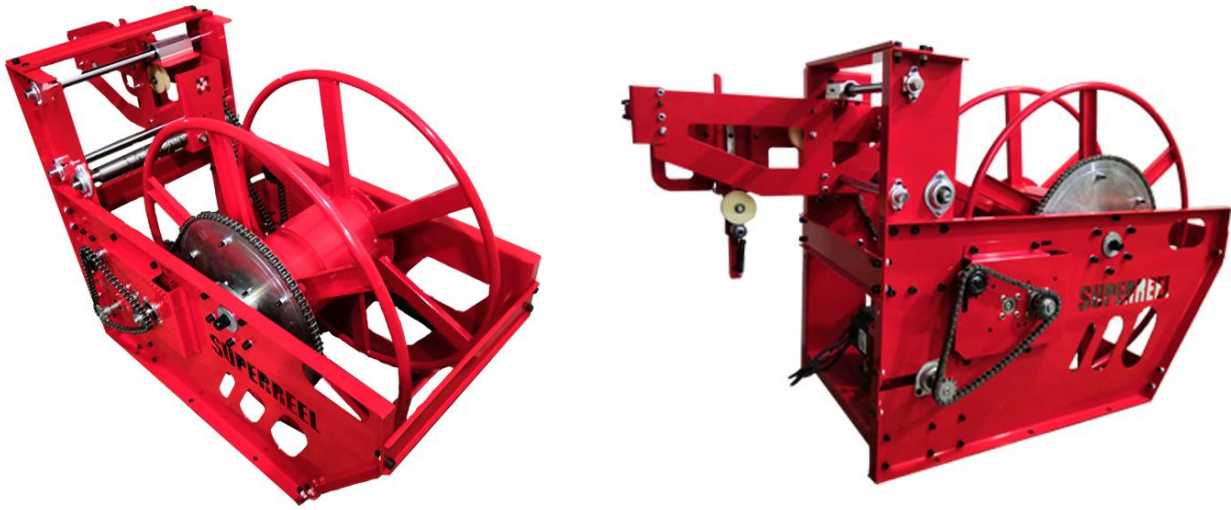

## FEATURES

- To handle live electric cable/cord.
- Automation, Powered by electric motor. Large capacity, Adaptive system.
- Silver alloy slip ring.
- Durable abrasion and corrosion resistant baked-on power coat finish.
- Rugged construction: Steel drum and all bolted construction. Vibration-proof self-locking fasteners.
- Low maintenance: Dual main bearings never need lubrication.
- Compact for critical space requirements.
- Shipped completely assembled, ready to install.



# Superreel® - Industrial Reel

## DIMENSIONS

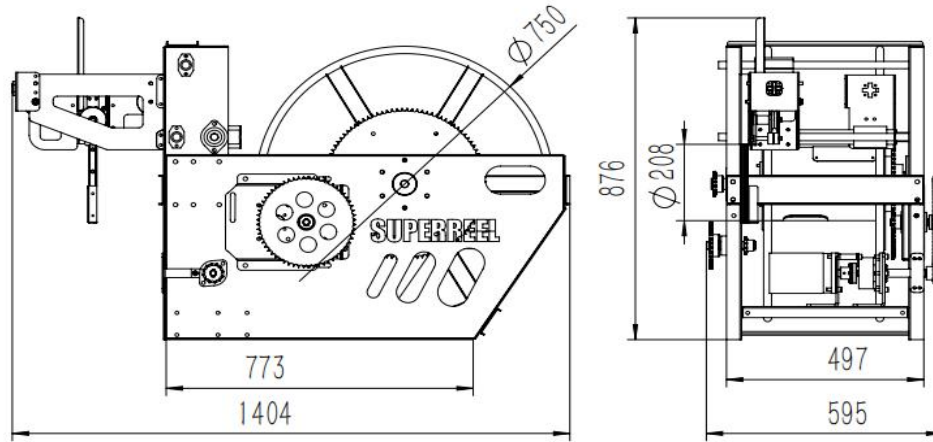

P/N	Port&core number	HOSE-ID. or CABLE-square	Pressure or lmax	Working length	Reel inlet	Cable outlet	A	B	C	D	E	F	G	H	I	J	K
EESC750D0805010900	8	1.5 <sup>2</sup>	10A	900m	Bare wire	Bare wire	750	208	876	595	1404	497	773	457	700	4	12
EESC750D0408030600	4	4 <sup>2</sup>	30A	600m	Bare wire	Bare wire	750	208	876	595	1404	497	773	457	700	4	12
220VAC							Dimensions are in millimeters										

